

# Newborn Screening

*Lesley Tetlow*

*Paediatric Biochemistry*

*Central Manchester Foundation Trust*

# Screening - Definition and Background

- Screening is a process of identifying apparently healthy people who may be at increased risk of a disease or condition. They can then be offered information, further tests and/or treatment to reduce their risk and/or complications.
- Screening is never 100% sensitive or specific. In any screening programme there is a minimum of false positive and false negative results.
- The UK National Screening Committee advises ministers and the NHS in all 4 countries about all aspects of screening policy.
- It assesses the evidence for programmes against defined criteria. These are an extended version of the Wilson and Junger criteria (first defined in 1968) and can be viewed in full on the UK National Screening Committee website ([www.screening.nhs.uk/criteria](http://www.screening.nhs.uk/criteria))
- Screening programmes are grouped into 6 broad categories. The Antenatal and Newborn category includes Newborn Blood Spot screening.

# Wilson and Junger's Criteria for a Screenable Disease

1. The condition sought should be an important health problem.
2. There must be an accepted and effective treatment for patients with the disease, that must be more effective at preventing morbidity when initiated in the early asymptomatic stage than when begun in the later symptomatic stages.
3. Facilities for diagnosis and treatment should be available.
4. There must be an appropriate, acceptable, and reasonably accurate screening test.
5. The natural history of the condition, including development from latent to manifest disease, should be adequately understood.
6. The cost of case-finding (including diagnosis and treatment of patients diagnosed) should be economically balanced in relation to possible expenditure on medical care as a whole.

# Newborn Bloodspot Screening Process

- Babies are screened by testing a capillary sample of blood obtained by a heel-prick stab - this is collected on to a card to form dried blood spots.
- In the UK babies are tested at 5-8 days of age - in other countries the practice is to test earlier.
- There are some differences across the UK in terms of the specific conditions screened for since each part of the UK can decide when and how to implement UK National Screening Committee policies.
- Screening laboratories test a population of 25,000 - >100,000.
- Organisation of screening into a limited number of laboratories serving a defined minimum population is cost-effective, concentrates experience and information, facilitates audit and promotes development of expertise for these relatively rare disorders.
- In addition to analysis and reporting, the screening lab provides an advisory service, conducts clinical audit and is involved in teaching and training of other health professionals involved in the service.

## Northern Ireland

Universal screening offered for phenylketonuria (PKU), congenital hypothyroidism (CHT), cystic fibrosis (CF), homocystinuria and tyrosinaemia. Medium chain acyl co-A dehydrogenase deficiency (MCADD) screening will commence in August 2009 and sickle cell disease (SCD) screening in April 2010.

## Scotland

Universal screening offered for phenylketonuria (PKU), congenital hypothyroidism (CHT) and cystic fibrosis (CF). Sickle cell disease (SCD) and medium-chain acyl-CoA dehydrogenase deficiency (MCADD) screening will be available from 2011.

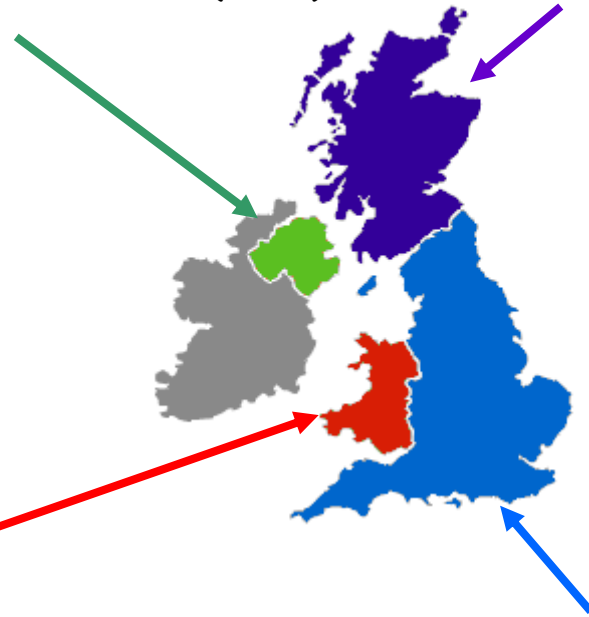

## Wales

Universal screening offered for phenylketonuria (PKU), congenital hypothyroidism (CHT) and cystic fibrosis (CF). In addition, Duchenne Muscular Dystrophy screening (boys only) is offered as part of routine care.

## England

Universal screening offered for phenylketonuria (PKU), congenital hypothyroidism (CHT), sickle cell disease (SCD), cystic fibrosis (CF) and medium-chain acyl-CoA dehydrogenase deficiency (MCADD).

# Newborn Bloodspot Screening Card

**NEWBORN SCREENING BLOOD TEST**

Baby's NHS No.

SURNAME													BABY'S D.O.B.		DATE OF SPECIMEN	
FORENAMES															Is this a repeat (✓)	
HOME ADDRESS													ETHNIC CATEGORY		Has baby had a blood transfusion (✓)	
													RANK		If YES date of last transfusion	
													GEST		Is the baby in hospital (✓)	
													/ 40		If YES, Current Hospital	
POSTCODE													SEX (✓) M F		BIRTH WEIGHT (g)	
Area or code													Hospital of Birth		Paediatrician	
G.P. NAME & INITIALS													MOTHER'S FULL NAME		Hospital Ward	
G.P. ADDRESS													MOTHER'S DOB		COMMENTS (eg. drug therapy, family history, temporary address, high risk)	
													MOTHER'S NHS No.		Name of person taking sample (Print)	
															Your contact Tel. No.	
PRACTICE CODE													BABY'S ALTERNATIVE SURNAME		SN	

077818918

077818918

SN



UKNSLN

2009-05



Surname: \_\_\_\_\_

Whatman GmbH  
 Hannestraße 3  
 37586 Dassel  
 Germany  
 Authorised By: The UK Newborn Screening  
 Laboratories Network (Ref. #742549)

# Individual Programmes Phenylketonuria (PKU)

PKU is an autosomal recessive condition caused by a deficiency of phenylalanine hydroxylase. There are >400 different mutations resulting in 0-25% enzyme activity and its incidence in UK is approximately 1 in 10,000 births.

In affected babies, phenylalanine accumulates rapidly following commencement of milk feeding which if untreated this leads to severe and irreversible learning difficulties.

Bloodspot phenylalanine level >240mmol/L considered a positive screen.  
All labs now use Tandem MS to measure phenylalanine levels.

Diagnostic confirmation is based on the plasma phenylalanine concentration:

- Classical PKU: phenylalanine >1200mmol/L that requires treatment
- Hyperphenylalaninaemia (HPA): phenylalanine 600-1200 mmol/L that requires treatment:
- Mild hyperphenylalaninaemia: phenylalanine <600mmol/L which may not require treatment:

# Metabolism of Phenylalanine

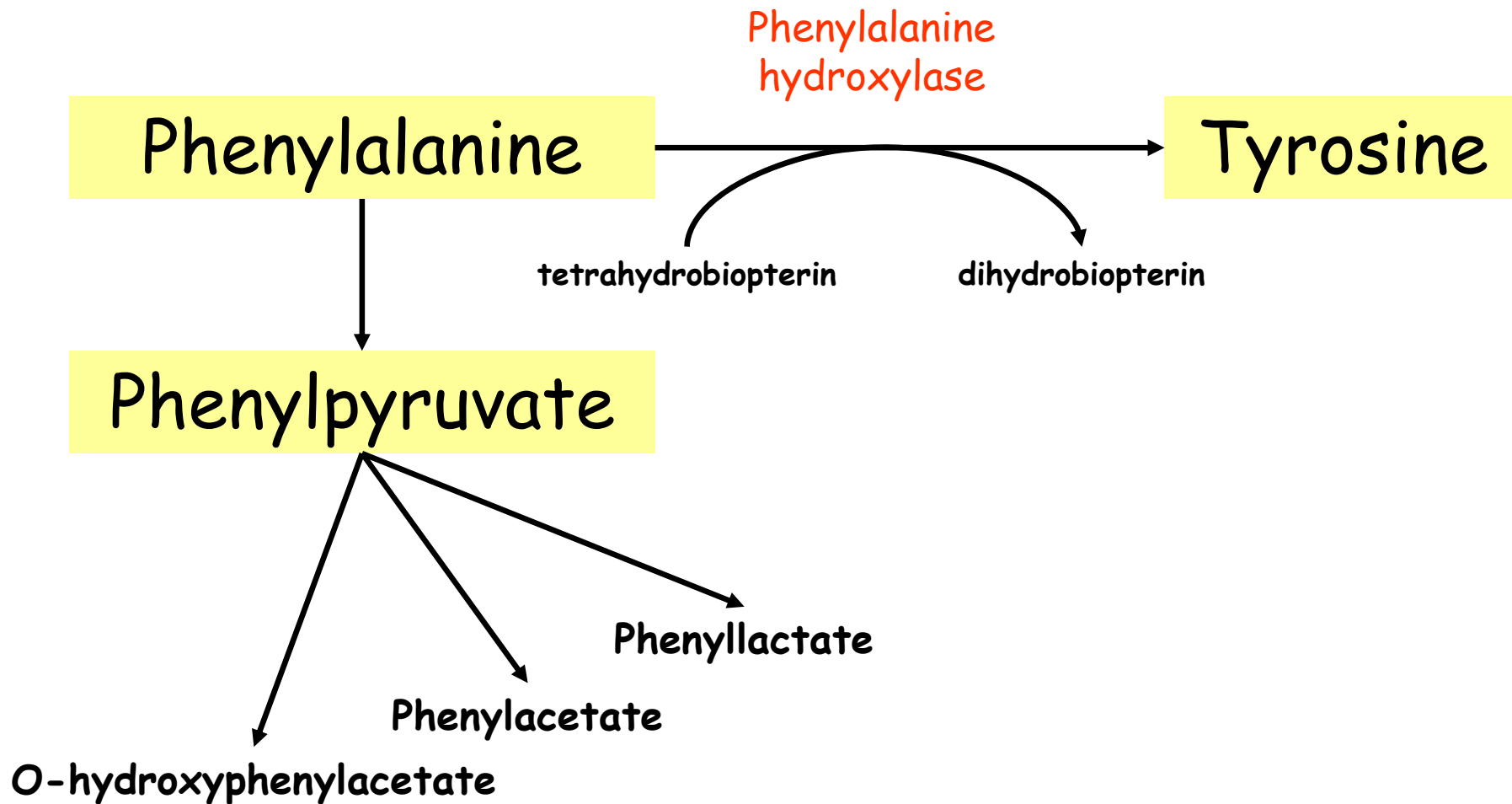

## Treatment for PKU

Dietary treatment needs to commence as soon as possible (at latest by 21 days) for optimal outcome. The basis of diet is a low phenylalanine content, supplemented with a protein substitute (either a mixture of free L-amino acids or a protein hydrolysate free from phenylalanine). A small and controlled amount of phenylalanine is required for normal growth and development - in neonate this is provided by breast or formula milk.

In early infancy, plasma phenylalanine should be maintained between 120-360  $\mu\text{mol/L}$ , the diet may be relaxed after 10 years of age but the desirability of this is controversial.

With early treatment and good dietary management, growth and development are normal however the diet must be strictly controlled in pregnancy to avoid severe foetal damage.

# Individual Programmes Congenital Hypothyroidism (CHT)

CHT is defined as defective function of the thyroid gland from birth. Its incidence is approximately 1 in 4000 and it is the most common treatable cause of mental retardation.

The majority of cases are sporadic - therefore it is not possible to predict which infants are likely to be affected.

There are two forms:-

Primary hypothyroidism: caused by a defect in thyroid gland leading to a failure of thyroid gland to produce T4 with consequentially high Thyroid Stimulating Hormone(TSH) concentrations.

Secondary hypothyroidism: due to a defect in the pituitary gland leading to inappropriately low TSH concentrations.

UK screening programmes detect elevated TSH using Dissociation Enhanced FluoroImmunoAssay (DELFI) technology. This is more sensitive than screening using T4 but does not pick up secondary hypothyroidism. However the latter is rare (approx 1 in 40,000 cases).

The plasma TSH concentration is high at birth and declines over the first week. It has usually stabilised by day 5. Hence programmes that test earlier may have poorer sensitivity and specificity.

# Control and Secretion of Thyroid Hormones

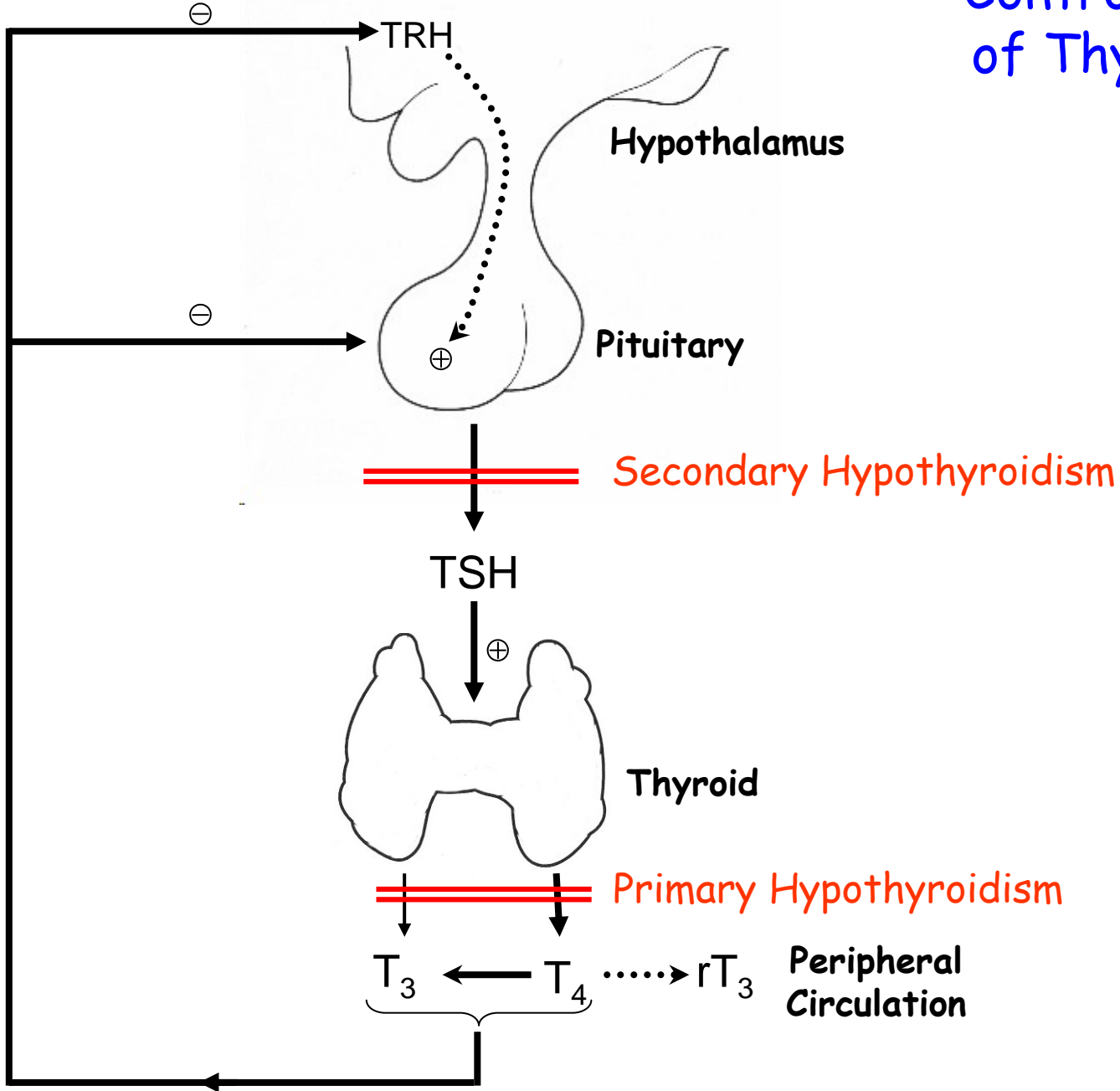

## Clinical Manifestations of CHT

- >95% newborn infants with CHT have few if any clinical manifestations.
- The symptoms may include lethargy, slow movement, hoarse cry, feeding problems, constipation, macroglossia, umbilical hernia, large fontanelles, hypotonia, dry skin, hypothermia and prolonged jaundice.
- There is also an increased risk of additional congenital malformations (4X higher than in control infant population).

# Treatment and Prognosis

- Thyroxine treatment should commence as soon as possible (and at least by 21 days).
- Oral T4 is treatment of choice - using a recommended starting dose of  $10\mu\text{g}/\text{kg}/\text{day}$  (which usually equates to  $37.5\mu\text{g}/\text{day}$ ).
- It aims to restore serum T4 concentration as rapidly as possible to the normal range followed by continued biochemical euthyroidism.
- Once treatment has started, it is recommended that baby is reviewed at 2 weeks, 6 weeks, 3 months, 6 months and 12 months with blood test at each visit.
- Psychometric outcome is now much improved over the pre-screening era, but some severely affected infants or those who are inadequately treated in the first 2-3 years of life have IQs below those of unaffected children.

# Individual Programmes

## Sickle Cell Disease (SCD)

Haemoglobinopathies are disorders of the haemoglobin gene and are of two types:

1. Structural variants of either the  $\beta$  or  $\alpha$  globin chains which make up the haemoglobin molecule - sickle cell disorders fall into this category.
2. An absence or reduction in production of normal  $\beta$  or  $\alpha$ -globin chains - these are the thalassaemias.

# Sickle Cell Disorders

Sickle Cell Disorders have an incidence of approximately 1 in 2,500 in the UK. They are due to a genetic variation of  $\beta$  globin chain, and all patients have in common the inheritance of one allele for the common sickle cell mutation c.20A>T (p.Glu6Val).

Most patients with sickle cell anaemia are homozygous (SS) for this mutation. However, in some, the interaction of sickle haemoglobin with other  $\beta$ -globin abnormalities (e.g. haemoglobin SC disease, HbS<sup>O<sup>arab</sup></sup>, HbS<sup>D<sup>punjab</sup></sup> and HbS/ $\beta$ thal) leads to the disorder.

These abnormalities cause the haemoglobin Hb molecule to become unstable in low oxygen conditions, leading to the formation of insoluble rigid chains. This produces "sickling" and destruction of the red cell, leading to occlusion of small blood vessels by sickled red cells.

# Sickle cell disease: clinical problems

- Anaemia
- Infections
- Painful crises
- Stroke
- Leg ulcers
- Visual loss
- Chronic organ damage
  - Kidneys
  - Lungs
  - Joints
  - Heart

## Prognosis and Treatment

The median survival age in UK in 1970's was the early 20's but now improvements in healthcare allow survival to the mid to late 40's.

Sickle cell anaemia is a very variable disorder. The severity of symptoms may vary through a person's life and between individuals with the same genetic disorder. Patients with milder forms of the disease may not present until adult life.

Prophylactic medicine, knowledge of the condition, proper crisis intervention and expert management can alleviate complications.

The main intervention is the reduction of the incidence of pneumococcal and other infections by the early introduction of antibiotics and by specific immunisation.

# Screening for Sickle Cell Disorders

Screening must be able to pick up Hbs A, F and S, C, D<sup>Punjab</sup>, O<sup>Arab</sup> in order to detect the major sickle cell disorders.

The recommended methods for detection are High Performance Liquid Chromatography (HPLC) or Isoelectric Focusing (IEF).

Some different types of haemoglobin have the same retention time or isoelectric point. Therefore all positive results have to be confirmed by a second different analytical technique. HPLC may be used for screening and IEF for confirmation or vice versa.

Transfused infants must be tested >4 months after the last transfusion.

# Individual Programmes

## Cystic Fibrosis (CF)

Cystic Fibrosis is caused by a defect in the cystic fibrosis transmembrane conductance regulator (CFTR) gene and has an incidence of approximately 1 in 2500

The gene defect results in abnormal transepithelial salt transport leading to changes in ion transport with a net increase in water absorption and thick secretions, which clog the ducts of mucus glands throughout the body.

It is a multi-system disorder but the main organs affected are the lungs and the GI tract. This is characterised by malabsorption of fat and protein, steatorrhoea, growth failure and pulmonary infection. Lung disease is major cause of morbidity and mortality.

## Treatment and Prognosis

There is no "cure" for CF but life expectancy has increased significantly by improved therapeutic interventions i.e.

- improved nutrition by providing pancreatic enzyme supplements to aid digestion.
- the reduction chest infections with frequent physiotherapy and antibiotic treatments (by intravenous and nebulised routes).

As a result the median life expectancy is now 31 years and in recent years, evidence in support of the benefits of early treatment has been accumulating.

# CF Screening Protocol

The protocol for screening for CF is complex.

It involves measuring both bloodspot immunoreactive trypsinogen (IRT) and DNA mutation analysis.

This is designed to :

- maximise the diagnosis of CFTR defects producing preventable/treatable disease.
- minimise detection of both unaffected heterozygotes (carriers) and mild defects producing late-onset disease.

The protocol initially involves quantitation of IRT on a bloodspot.

If the IRT concentration is high DNA analysis is then performed.

DNA analysis is conducted in 2 stages

Initially four common mutations are tested for - this is followed up by testing for a 31 mutation panel of mutations only in those with one of the four common mutations.

Sweat tests are then performed on babies with two mutations to confirm CF.

# Individual Programmes

## Medium Chain Acyl CoA Dehydrogenase Deficiency (MCADD)

MCADD is an autosomal recessively inherited defect of fatty acid oxidation with an incidence in the UK between 1 in 10,000 and 1 in 20,000

In patients with MCADD there is a deficiency of the fatty acid beta oxidation enzyme medium-chain-acyl-CoA dehydrogenase. Mitochondrial fatty acid beta oxidation enables the body to use its own fat reserves to produce energy in periods of fasting/stress.

A deficiency of medium chain acylCoA dehydrogenase causes a block in the medium chain length step of fat oxidation (carbon chain lengths C6-C12) which leads to a build up of medium-chain fatty acids, in particular octanoylcarnitine (C8) and its metabolites.

MCADD screening is based on the quantitative measurement of octanoylcarnitine (C8) by Liquid Chromatography Tandem Mass Spectrometry (LC/MS/MS). If this is elevated confirmation is by repeat analysis in a blood sample with analysis of the MCADD gene for a common mutation and, if necessary, full mutation screening.

# Medium chain fatty acid metabolism in fat oxidation defects

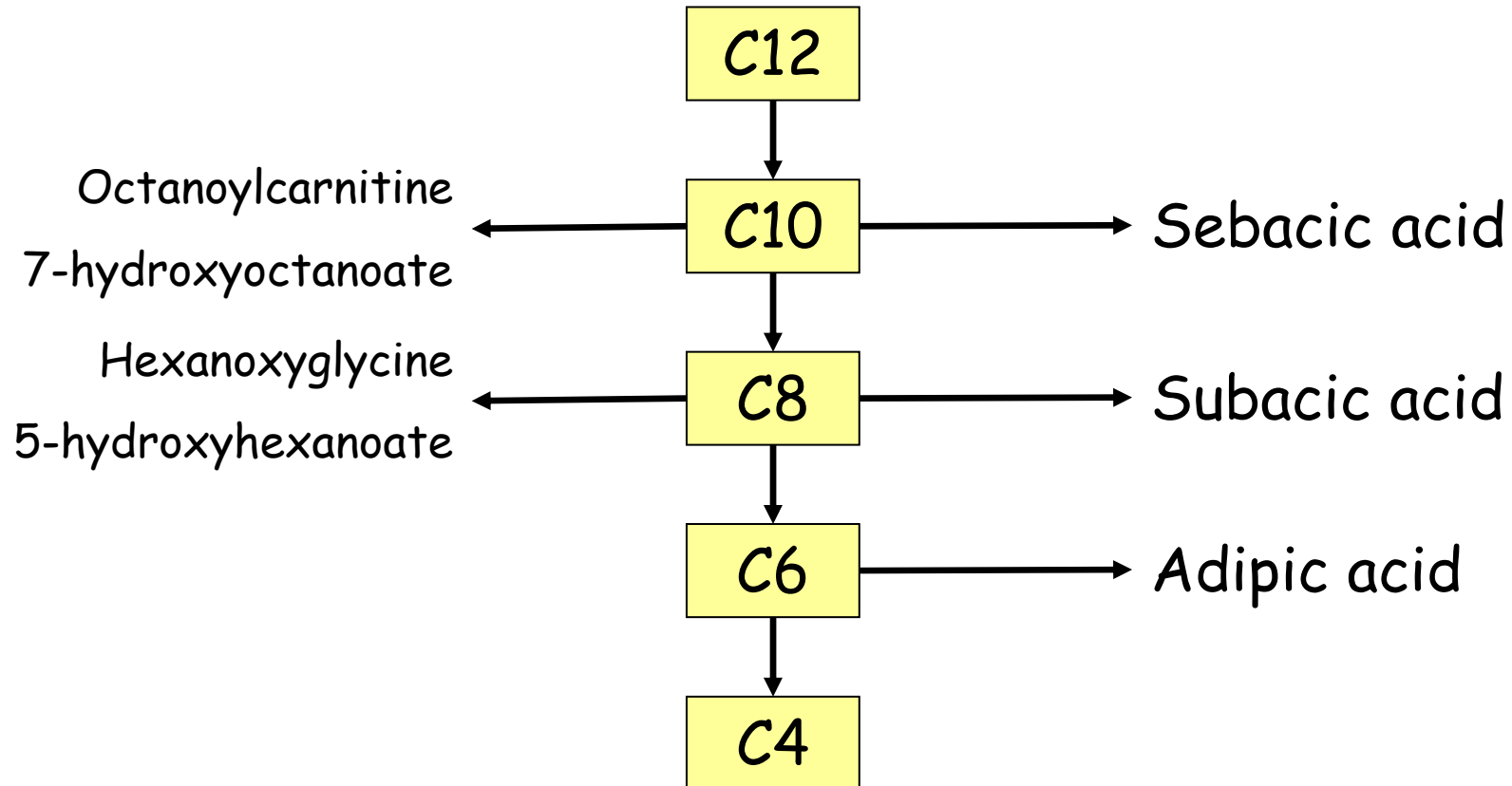

# Clinical Manifestations of MCADD Deficiency

- Clinical symptoms typically occur as a result of illnesses or situations associated with fasting and/or vomiting when it is essential to break down fat quickly.
- Severe hypoglycaemia develops often with hypoketosis which may progress to Reye's Syndrome with acidosis: a raised blood ammonia and abnormal liver function tests may also be present.
- Seizures, brain damage and ultimately death may result.
- MCADD typically presents before 2 years of age- mean age of presentation is 13 months but it can present in the neonatal period.
- Treatment involves the avoidance of fasting by following a strict feeding schedule and monitoring in order to determine "safe" time periods between meals. Families are taught to use an emergency regimen during periods of intercurrent illness.
- The long term prognosis is very good once diagnosed provided the emergency regimen is followed as directed.

# Self Assessment Questions

1. What is the definition of screening?
2. In the UK, at what age are samples taken for newborn bloodspot screening?
3. In England which five conditions are screened for in the newborn?
4. Which enzyme is deficient in phenylketonuria (PKU)?
5. Within what limits should plasma phenylalanine be maintained in an infant on treatment for PKU?
6. How is congenital hypothyroidism inherited?
7. In newborn screening for congenital hypothyroidism what technique is used to measure TSH?
8. Name the two types of haemoglobinopathies.
9. Which are the two main organs affected in cystic fibrosis?
10. In MCADD deficiency when do symptoms typically occur?

## Self Assessment Answers

1. A process of identifying apparently healthy people who may be at increased risk of a disease or condition.
2. 5 - 8 days.
3. Phenylketonuria (PKU), congenital hypothyroidism (CHT), sickle cell disease (SCD), cystic fibrosis (CF) and medium-chain acyl-CoA dehydrogenase deficiency (MCADD).
4. Phenylalanine hydroxylase.
5. 120 - 360  $\mu\text{mol/L}$ .
6. The majority of cases are sporadic.
7. Dissociation Enhanced Lanthanide FluoroImmuoAssay (DELFI~~A~~).
8. Sickle cell disorders (structural variants of  $\beta$  or  $\alpha$  globin chain) and thalassaemias (absence or reduction of normal  $\beta$  or  $\alpha$  globin chain).
9. Lungs and GI tract.
10. As a result of illness or situations associated with fasting and/or vomiting when it is essential to break down fat quickly.